



Rani Tool Corp.



DTS GmbH

Diamond Tooling Systems

Winter SALE

WARM UP WITH THESE HOT DEALS!



Innovative Solutions for High Productivity

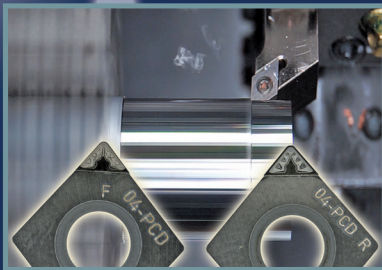

PCD / CVD-D Inserts with Laser Chipbreakers

Page 2



Multi-Tipped CBN Inserts

Page 6

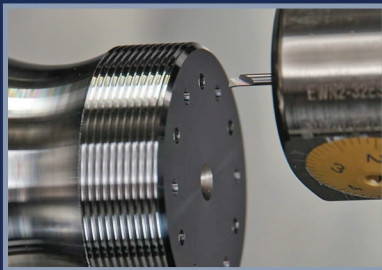

PCD / CVD-D / CBN Tipped Boring Bars

Page 10

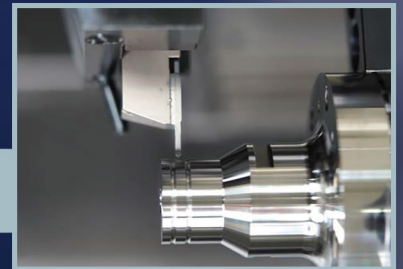

Micro-Line Grooving System

Page 14

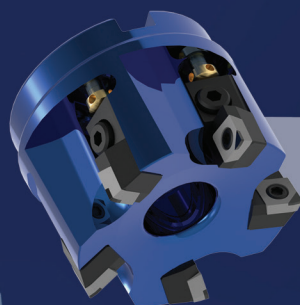

High Speed Milling with PCD / CBN

Page 18

RTC *Rani Tool Corp.*



DTS GmbH

Diamond Tooling Systems



PASSION FOR DIAMOND

CVD-D & PCD Chipbreaker Program

Introducing 2 Brand New Lasered Chipbreakers

- Over 250 new line items
- Greatly expanded offering of full edge inserts with chipbreakers
- PCD and CVD-D binderless diamond
- Wipers available for 80° and 55° inserts for up to 2 to 4 times higher feed rates with good surface finishes
- Can be used in smooth and interrupted cutting
- CBF chipbreaker has sharp cutting edges and produces minimal cutting pressure on thin-walled parts
- CBR chipbreaker has a landed edge for strength and produces excellent part finishes

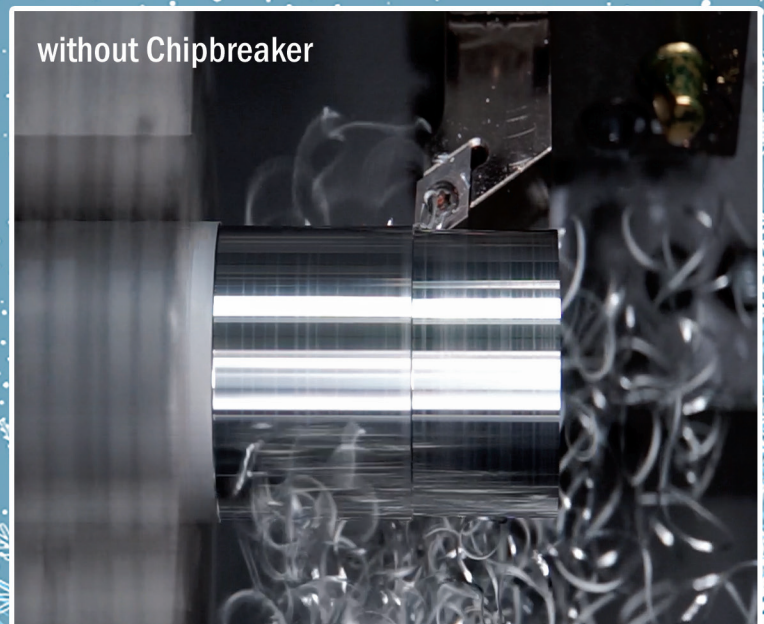
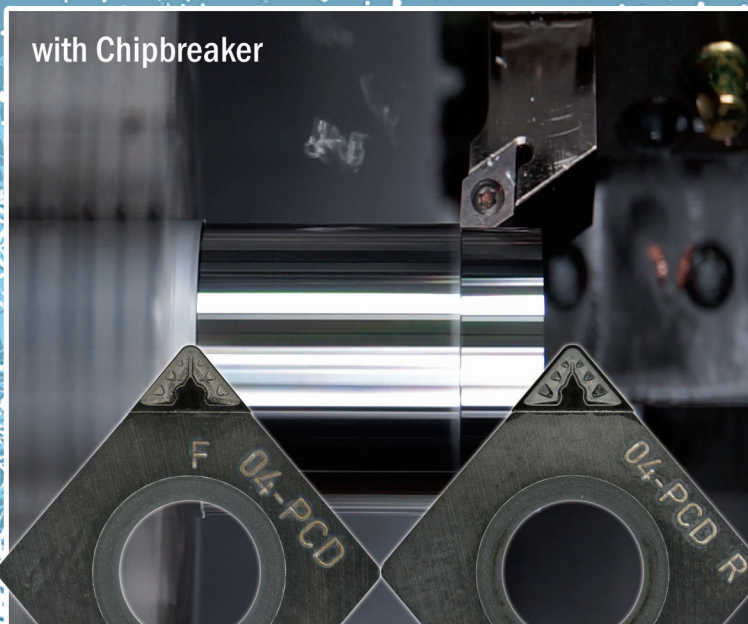

CVD-D & PCD Chipbreaker Program

CCGT Positive Rake Angle

Designation	IC	S	r	PCD		CVD-D		CL	PDC	PDC-S	PDC-CU-S
				CBF	CBR	CBF	CBR		CB1	CB2	CB3
CCGT-21.50.5	.250	.094	.008	■	■	■	■				
CCGT-21.50.5L-GS			.008	■	■	■	■				
CCGT-21.50.5R-GS			.008	■	■	■	■				
CCGT-21.50.5W			.008	■	■						
CCGT-21.51			.016	■	■	■	■				
CCGT-21.51L-GS			.016	■	■	■	■				
CCGT-21.51R-GS			.016	■	■	■	■				
CCGT-21.51W			.016	■	■						
CCGT-21.52			.031	■	■	■	■				
CCGT-21.52L-GS			.031	■	■	■	■				
CCGT-21.52R-GS	.031	■	■	■	■						
CCGT-32.50.5	.375	.156	.008	■	■	■	■	.177	■		
CCGT-32.50.5W			.008	■	■			.177		■	
CCGT-32.51			.016	■	■	■	■		■	■	■
CCGT-32.51L-GS			.016	■	■	■	■				
CCGT-32.51R-GS			.016	■	■	■	■				
CCGT-32.51W			.016	■	■						
CCGT-32.52			.031	■	■	■	■	.161		■	■
CCGT-32.52L-GS			.031	■	■	■	■				
CCGT-32.52R-GS			.031	■	■	■	■				
CCGT-32.52W			.031	■	■						
CCGT-430.5	.500	.187	.008	■	■	■	■				
CCGT-430.5W			.008	■	■						
CCGT-431			.016	■	■	■	■				
CCGT-431L-GS			.016	■	■	■	■				
CCGT-431R-GS			.016	■	■	■	■				
CCGT-431W			.016	■	■						
CCGT-432			.031	■	■	■	■	.161	■	■	
CCGT-432L-GS			.031	■	■	■	■				
CCGT-432R-GS			.031	■	■	■	■				
CCGT-432W			.031	■	■						

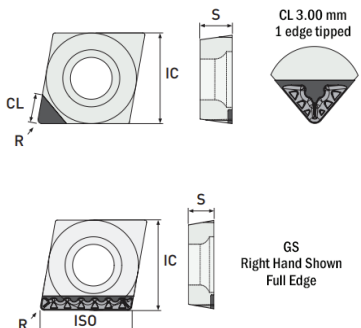

CPGT Positive Rake Angle • Edge Tipped

Designation	IC	S	r	PCD		CVD-D		CL	PDC	PDC-S	PDC-CU-S
				CBF	CBR	CBF	CBR		CB1	CB2	CB3
CPGT-21.50.5	.250	.094	.008	■	■	■	■				
CPGT-21.51			.016	■	■	■	■				
CPGT-21.52			.031	■	■	■	■				
CPGT-32.50.5	.375	.156	.008	■	■	■	■				
CPGT-32.51			.016	■	■	■	■				
CPGT-32.52			.031	■	■	■	■				
CPGT-431	.500	.187	.016	■	■	■	■				
CPGT-432			.031	■	■	■	■				

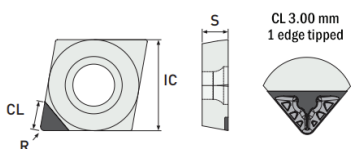

CVD-D & PCD Chipbreaker Program

DCGT Positive Rake Angle • Edge Tipped

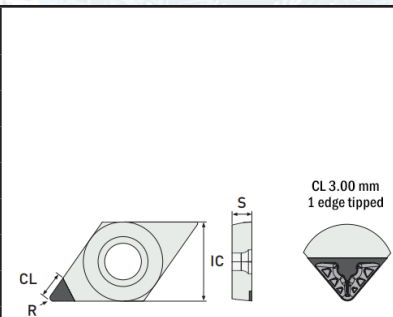
	Designation	IC	S	r	PCD		CVD-D		CL	PDC	PDC-S	PDC-CU-S
					CBF	CBR	CBF	CBR		CB1	CB2	CB3
	DCGT-21.50.5	.250	.094	.008	■	■	■	■	.146	■		
	DCGT-21.50.5W				■	■	■	■				
	DCGT-21.51				■	■	■	■				
	DCGT-21.51W				■	■	■	■				
	DCGT-21.52				■	■	■	■				
	DCGT-21.52W				■	■	■	■				
	DCGT-32.50.5	.375	.156	.008	■	■	■	■	.185	■	■	
	DCGT-32.50.5W				■	■	■	■				
	DCGT-32.51				■	■	■	■	.169	■	■	■
	DCGT-32.51W				■	■	■	■				
	DCGT-32.52				■	■	■	■				
	DCGT-32.52W				■	■	■	■				

TCGT Positive Rake Angle

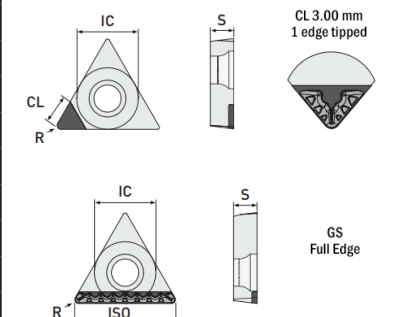
	Designation	IC	S	r	PCD		CVD-D		CL	PDC	PDC-S	PDC-CU-S
					CBF	CBR	CBF	CBR		CB1	CB2	CB3
	TCGT-1.81.50.5	.219	.094	.008	■	■						
	TCGT-1.81.50.5-GS				■	■						
	TCGT-1.81.51				■	■						
	TCGT-1.81.51-GS				■	■						
	TCGT-1.81.52				■	■						
	TCGT-1.81.52-GS				■	■						
	TCGT-21.50.5	.250	.094	.008	■	■						
	TCGT-21.50.5-GS				■	■						
	TCGT-21.51				■	■						
	TCGT-21.51-GS				■	■						
	TCGT-21.52				■	■						
	TCGT-21.52-GS				■	■						
	TCGT-32.50.5	.375	.156	.008	■	■						
	TCGT-32.50.5-GS				■	■						
	TCGT-32.51				■	■						
	TCGT-32.51-GS				■	■						
	TCGT-32.52				■	■						
	TCGT-32.52-GS				■	■						

VBGT* / VCGT** Positive Rake Angle

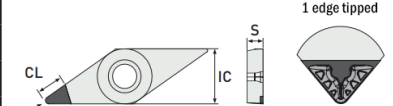
	Designation	IC	S	r	PCD		CVD-D		CL	PDC	PDC-S	PDC-CU-S
					CBF	CBR	CBF	CBR		CB1	CB2	CB3
	VBGT-330.5	.375	.187	.008					.232	■		
	VBGT-331			.016					.216	■		
	VCGT-1.21.50.5	.156	.094	.008	■	■	■	■				
	VCGT-1.21.51			.016	■	■	■	■				
	VCGT-1.21.52			.031	■	■	■	■				
	VCGT-220.5	.250	.125	.008	■	■	■	■				
	VCGT-221			.016	■	■	■	■				
	VCGT-222			.031	■	■	■	■				
	VCGT-330.5	.375	.187	.008	■	■	■	■				
	VCGT-331			.016	■	■	■	■				
	VCGT-332			.031	■	■	■	■	.216		■	

* VBGT inserts have 5-degree side rake, ** VCGT inserts have 7-degree side rake

Technical Information

Grade	Description	Application
PCD / PDC / PDC-S / PDC-CU-S	Polycrystalline diamond is a synthetically produced product that is an extremely tough, intergrown mass of diamond particles with random orientation in a metal matrix. Polycrystalline grades have high thermal conductivity and provide good heat dissipation away from the cutting edge.	These grades are well suited for machining aluminum with Si content up to 10% and other abrasive fillers. Used in all non-ferrous applications.
CVD-D	CVD-D is one of the hardest man-made diamond cutting materials. Due to the lack of bonding matrix CVD-D has a much higher content than the polycrystalline diamond grades. Tool life can be up to 10 times that of other PCD style grades.	For the machining of hard brittle materials such as ceramics, glass, glass ceramics, tungsten carbide, MMC and fiber reinforced composites such as CFRP and GFRP.

Chipbreaker Cutting Information

Chipbreaker Designation	Description	Nose Radius	D.O.C Min - Max	Feed per Rev. Min - Max
CBF / CB1	Finish to medium finish machining with low cutting forces due to the sharp cutting edge. Burr free machining is possible and produces exceptional surface finishes.	.008"	.0004" - .110"	.0008" - .004"
		.016"	.0004" - .110"	.0015" - .008"
		.031"	.0004" - .110"	.002" - .016"
		.047"	.0004" - .110"	.002" - .024"
CBR / CB2	General purpose machining. Strong cutting edge for higher depths of cut and feed rates while producing high surface quality.	.008"	.002" - .110"	.001" - .004"
		.016"	.0023" - .110"	.001" - .008"
		.031"	.003" - .110"	.0023" - .016"
		.047"	.004" - .110"	.003" - .023"
CB3	Wave design chipbreaker generates constant chip breaking during the roughing process. Only for thick walled workpieces under stable conditions.	.016"	.040" - .110"	.008" - .010"
		.031"	.040" - .110"	.008" - .015"

Speed Information

Materials	CVD-D (Vc: SFM)	PCD (Vc: SFM)
Non-Ferrous metals, aluminum alloys without silicon	1600 - 15000	1300 - 8000
Non-Ferrous metals, aluminum alloys with less than 12% silicon	1300 - 11000	1300 - 6500
Non-Ferrous metals, aluminum alloys with more than 12% silicon	1300 - 6000	
Brass, bronze, copper, copper alloys, precious metals	1300 - 7000	975 - 5800
Non-metallics, pure plastics without reinforcements	1300 - 6000	975 - 3900
Non-metallics, plastics with reinforcements	650-4500	



12 Brand New CBN Grades greatly expanding our already impressive product offering!

- Over 1,000 New line items
- Grades for hard steel, powdered metal, hi-temp alloys
- Grey & ductile cast iron
- Smooth and highly interrupted cut
- Multiple cutting edges on each insert

CCGW Edge Tipped

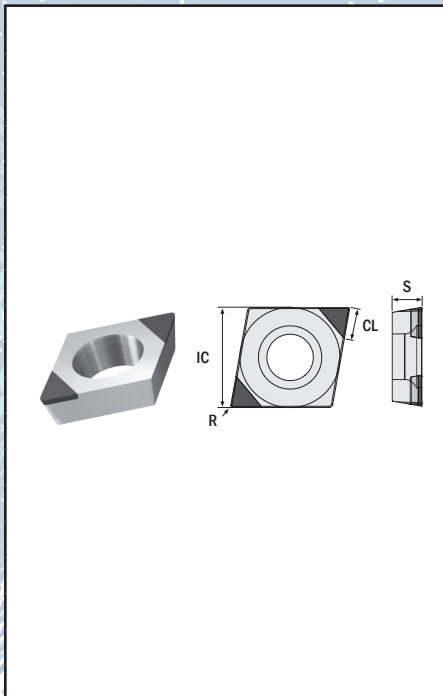

Designation	IC	S	CL	r	H25BL	H35BL	H45BL	H65BL	H85BL	K65BH	K85BH	P25BH	P45BH	S85BH	X90BH	X95BH		
CCGW-21.50-2	.250	.094	.118	.004	■					■	■	■	■	■	■	■		
CCGW-21.50.5-2				.008	■	■	■	■	■	■	■	■	■	■	■	■	■	■
CCGW-21.51-2				.016	■	■	■	■	■	■	■	■	■	■	■	■	■	■
CCGW-21.52-2				.031	■	■	■	■	■	■	■	■	■	■	■	■	■	■
CCGW-32.50-2	.375	.156	.118	.004	■					■	■	■	■	■	■	■		
CCGW-32.50.5-2				.008	■	■	■	■	■	■	■	■	■	■	■	■	■	■
CCGW-32.50.5W-2				.008					■	■	■	■	■	■	■	■	■	■
CCGW-32.51-2				.016	■	■	■	■	■	■	■	■	■	■	■	■	■	■
CCGW-32.51W-2				.016	■	■	■	■	■	■	■	■	■	■	■	■	■	■
CCGW-32.52-2				.031	■	■	■	■	■	■	■	■	■	■	■	■	■	■
CCGW-32.52W-2				.031	■	■	■	■	■	■	■	■	■	■	■	■	■	■
CCGW-430.5-2							.008	■	■	■	■	■	■	■	■	■	■	■
CCGW-431-2				.016	■	■	■	■	■	■	■	■	■	■	■	■		
CCGW-431W-2				.016	■	■	■	■	■	■	■	■	■	■	■	■		
CCGW-432-2	.500	.187	.118	.031	■	■	■	■	■	■	■	■	■	■	■	■		
CCGW-432W-2				.031	■	■	■	■	■	■	■	■	■	■	■	■	■	
CCGW-433-2				.047	■	■	■	■	■	■	■	■	■	■	■	■	■	■
CCGW-433W-2				.047	■	■	■	■	■	■	■	■	■	■	■	■	■	■

CBN Program

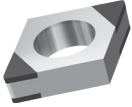
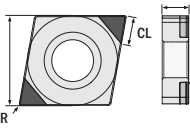

CNGA Edge Tipped

 	Designation	IC	S	CL	r	H25BL	H35BL	H45BL	H65BL	H85BL	K65BH	K85BH	P25BH	P45BH	S85BH	X90BH	X95BH		
	CNGA-430.5-4	.500	.187	.118	.008	■	■	■	■	■	■	■	■	■	■	■	■	■	
	CNGA-430.5W-4				.008	■	■	■	■	■	■	■	■	■	■	■	■	■	■
	CNGA-431-4				.016	■	■	■	■	■	■	■	■	■	■	■	■	■	■
	CNGA-431W-4				.016	■	■	■	■	■	■	■	■	■	■	■	■	■	■
	CNGA-432-4				.031	■	■	■	■	■	■	■	■	■	■	■	■	■	■
	CNGA-432W-4				.031	■	■	■	■	■	■	■	■	■	■	■	■	■	■
	CNGA-433-4				.047	■	■	■	■	■	■	■	■	■	■	■	■	■	■
	CNGA-433W-4				.047	■	■	■	■	■	■	■	■	■	■	■	■	■	■

DCGW Edge Tipped

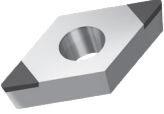
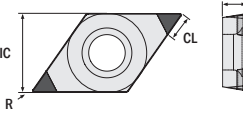
 	Designation	IC	S	CL	r	H25BL	H35BL	H45BL	H65BL	H85BL	K65BH	K85BH	P25BH	P45BH	S85BH	X90BH	X95BH			
	DCGW-21.50-2	.250	.094	.118	.004	■	■	■	■	■	■	■	■	■	■	■	■	■		
	DCGW-21.50.5-2				.008	■	■	■	■	■	■	■	■	■	■	■	■	■	■	
	DCGW-21.51-2				.016	■	■	■	■	■	■	■	■	■	■	■	■	■	■	
	DCGW-21.51W-2				.016	■	■	■	■	■	■	■	■	■	■	■	■	■	■	
	DCGW-21.52-2				.031	■	■	■	■	■	■	■	■	■	■	■	■	■	■	
	DCGW-21.52W				.031	■	■	■	■	■	■	■	■	■	■	■	■	■	■	
	DCGW-32.50-2				.375	.156	.118	.004	■	■	■	■	■	■	■	■	■	■	■	■
	DCGW-32.50.5-2							.008	■	■	■	■	■	■	■	■	■	■	■	■
	DCGW-32.51-2							.016	■	■	■	■	■	■	■	■	■	■	■	■
	DCGW-32.51W-2							.016	■	■	■	■	■	■	■	■	■	■	■	■
	DCGW-32.52-2							.031	■	■	■	■	■	■	■	■	■	■	■	■
	DCGW-32.52W-2							.031	■	■	■	■	■	■	■	■	■	■	■	■

DNGA Edge Tipped

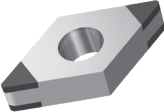
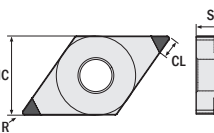
 	Designation	IC	S	CL	r	H25BL	H35BL	H45BL	H65BL	H85BL	K65BH	K85BH	P25BH	P45BH	S85BH	X90BH	X95BH
	DNGA-430.5-4	.500	.187	.118	.008	■	■	■	■	■	■	■	■	■	■	■	■
	DNGA-431-4				.016	■	■	■	■	■	■	■	■	■	■	■	■
	DNGA-431W-4				.016	■	■	■	■	■	■	■	■	■	■	■	■
	DNGA-432-4				.031	■	■	■	■	■	■	■	■	■	■	■	■
	DNGA-432W-4				.031	■	■	■	■	■	■	■	■	■	■	■	■
DNGA-433-4	.047				■	■	■	■	■	■	■	■	■	■	■	■	

SNGA Edge Tipped

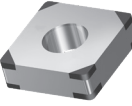
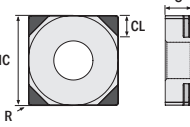
 	Designation	IC	S	CL	r	H25BL	H35BL	H45BL	H65BL	H85BL	K65BH	K85BH	P25BH	P45BH	S85BH	X90BH	X95BH
	SNGA-431-8	.500	.187	.118	.016	■	■	■	■	■	■	■	■	■	■	■	■
	SNGA-432-8				.031	■	■	■	■	■	■	■	■	■	■	■	■
	SNGA-433-8				.047	■	■	■	■	■	■	■	■	■	■	■	■

CBN Program



VNGA Edge Tipped

	Designation	IC	S	CL	r	H25BL	H35BL	H45BL	H65BL	H85BL	K65BH	K85BH	P25BH	P45BH	S85BH	X90BH	X95BH
	VNGA-330.5-4				.008	■		■	■	■	■	■	■	■		■	■
	VNGA-331-4				.016	■		■	■	■	■	■	■	■		■	■
	VNGA-332-4	.375	.187	.118	.031	■		■	■	■	■	■	■	■		■	■
	VNGA-333-4				.047	■		■	■	■	■	■	■	■		■	■

WNGA Edge Tipped

	Designation	IC	S	CL	r	H25BL	H35BL	H45BL	H65BL	H85BL	K65BH	K85BH	P25BH	P45BH	S85BH	X90BH	X95BH
	WNGA-430.5-6				.008	■		■	■	■	■	■	■	■		■	■
	WNGA-431-6				.016	■		■	■	■	■	■	■	■		■	■
	WNGA-431W-6				.016	■		■	■	■	■	■	■	■		■	■
	WNGA-432-6	.500	.187	.118	.031	■		■	■	■	■	■	■	■		■	■
	WNGA-432W				.031	■		■	■	■	■	■	■	■		■	■
	WNGA-433-6				.047	■		■	■	■	■	■	■	■		■	■
	WNGA-433W-6				.047	■		■	■	■	■	■	■	■		■	■

Cut Type

	Continuous Cut
	Light Interrupted Cut
	Heavy Interrupted Cut

Cooling Recommendations

Cut Type	Dry	Air	Emulsion	Oil
		3	BEST	2
	2	BEST	3	
	2	BEST		

All cut types for grade S85BH require cooling by emulsion

Technical Information

Grade	Cut Type	Materials	SFM	FPR	DOC
H25BL		Steel, Tool Steel, Bearing Steel, Hardened Sintered Steel, up to 72Rc	325 - 980	.0004" - .019"	.0004" - .059"
H35BL			325 - 850	.0004" - .019"	.0004" - .059"
H45BL			325 - 850	.0004" - .016"	.0004" - .039"
H65BL			325 - 780	.0004" - .016"	.0004" - .039"
H85BL			260 - 725	.0004" - .016"	.0004" - .039"
K65BH		Grey Cast Iron (GCI), Ductile Cast Iron (DCI)	955 - 7650	.0004" - .014"	.0004" - .100"
K85BH			760 - 5300	.0004" - .014"	.0004" - .100"
P25BH		Sintered Steel	650 - 1300	.0004" - .012"	.0004" - .100"
P45BH			590 - 985	.0004" - .012"	.0004" - .080"
S85BH		Hi-Temp Alloys, Ni, Co, Fe, Cr, based	300 - 1300	.0004" - .012"	.0004" - .020"
X90BH		Tool Steel up to 72Rc, Powdered Metal Steel hardened up to 72Rc, Stainless Steel hardened, Stellite	195 - 720	.0004" - .016"	.0004" - .080"
X95BH			130 - 590	.0004" - .012"	.0004" - .020"



Rani Tool Corp.



DTS GmbH

Diamond Tooling Systems



PASSION FOR DIAMOND

- Solid brazed style PCD/CVD-D/CBN tipped boring bars
- Over 250 line items
- Sizes start at 1mm minimum bore up through 9mm
- Nice range of 4 “reaches” to better match your applications
- Three different radii are standard

- Excellent cutting geometry to produce fine finishes and tight tolerances
- Bars have locating flats for easy alignment
- Two styles—BS and BE for a broader application range
- 5/8" diameter adapters are available

BS

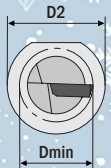
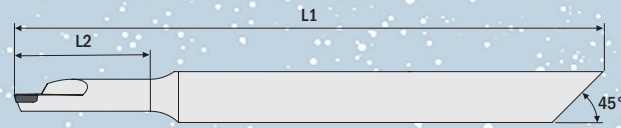
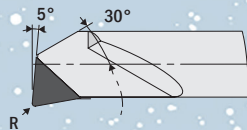

Figure Shown Right Hand Version

PASSION FOR DIAMOND

						PCD	CVD-D	CBN
Dmin	L2	L1	R	D2	Version	ITEM CODE	ITEM CODE	ITEM CODE
1	3	72	0.1	4 ^{H6}	RH		BS2050-1002	BS3550-1002
					LH		BS2050-1003	BS3550-1003
	10	80	0.1	4 ^{H6}	RH	BS1050-0000	BS2050-0000	BS3550-0000
					LH	BS1050-0001	BS2050-0001	BS3550-0001
1.5	3	71	0.1	4 ^{H6}	RH		BS2050-1007	BS3550-1007
					LH		BS2050-1008	BS3550-1008
	6	74	0.1	4 ^{H6}	RH		BS2050-1005	BS3550-1005
					LH		BS2050-1006	BS3550-1006
	15	80	0.1	4 ^{H6}	RH	BS1050-0005	BS2050-0005	BS3550-0005
					LH	BS1050-0006	BS2050-0006	BS3550-0006
2	6	74	0.1	4 ^{H6}	RH		BS2050-1012	BS3550-1012
					LH		BS2050-1013	BS3550-1013
	6	74	0.2	4 ^{H6}	RH		BS2050-2012	BS3550-2012
					LH		BS2050-2013	BS3550-2013
	10	80	0.1	4 ^{H6}	RH	BS1050-0010	BS2050-0010	BS3550-0010
					LH	BS1050-0011	BS2050-0011	BS3550-0011
2.5	6	74	0.1	4 ^{H6}	RH		BS2050-1022	BS3550-1022
					LH		BS2050-1023	BS3550-1023
	6	74	0.2	4 ^{H6}	RH		BS2050-2022	BS3550-2022
					LH		BS2050-2023	BS3550-2023
	10	80	0.1	4 ^{H6}	RH	BS1050-0020	BS2050-0020	BS3550-0020
					LH	BS1050-0021	BS2050-0021	BS3550-0021
3	6	74	0.1	4 ^{H6}	RH		BS2050-1028	BS3550-1028
					LH		BS2050-1029	BS3550-1029
	6	74	0.2	4 ^{H6}	RH		BS2050-2028	BS3550-2028
					LH		BS2050-2029	BS3550-2029
	10	78	0.1	4 ^{H6}	RH	BS1050-1026	BS2050-1026	BS3550-1026
					LH	BS1050-1027	BS2050-1027	BS3550-1027
	10	78	0.2	4 ^{H6}	RH	BS1050-2026	BS2050-2026	BS3550-2026
					LH	BS1050-2027	BS2050-2027	BS3550-2027
	15	83	0.1	4 ^{H6}	RH	BS1050-1024	BS2050-1024	BS3550-1024
					LH	BS1050-1025	BS2050-1025	BS3550-1025
15	83	0.2	4 ^{H6}	RH	BS1050-2024	BS2050-2024	BS3550-2024	
				LH	BS1050-2025	BS2050-2025	BS3550-2025	



- Precision machine a wide range of workpiece materials. PCD and CVD-D are used in low and high silicon aluminum alloys, all non-ferrous materials such as brass, carbide, ceramics, CFRP/GFRP, copper, graphite, MMC, PEEK, precious metals, Tungston alloys
- The CBN grade is used in hardened steel up to 68Rc, special alloys such as ASP, CPM, HARDOX, high temperature alloys, and hardened tool steels

BS

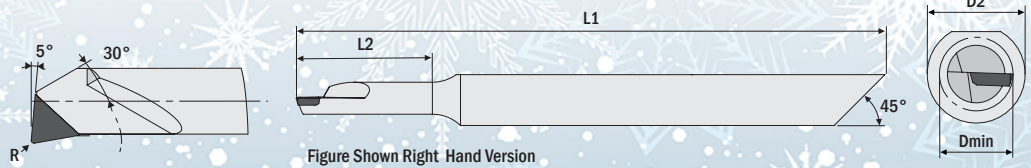

PASSION FOR DIAMOND

						PCD	CVD-D	CBN
Dmin	L2	L1	R	D2	Version	ITEM CODE	ITEM CODE	ITEM CODE
3.5	6	74	0.1	4 ^{H6}	RH		BS2050-1032	BS3550-1032
					LH		BS2050-1033	BS3550-1033
	6	74	0.2	4 ^{H6}	RH		BS2050-2032	BS3550-2032
					LH		BS2050-2033	BS3550-2033
	10	78	0.1	4 ^{H6}	RH		BS2050-1034	BS3550-1034
					LH		BS2050-1035	BS3550-1035
	10	78	0.2	4 ^{H6}	RH		BS2050-2034	BS3550-2034
					LH		BS2050-2035	BS3550-2035
	15	80	0.1	4 ^{H6}	RH	BS1050-0030	BS2050-0030	BS3550-0030
					LH	BS1050-0031	BS2050-0031	BS3550-0031
	15	83	0.2	4 ^{H6}	RH	BS1050-2030	BS2050-2030	BS3550-2030
					LH	BS1050-2031	BS2050-2031	BS3550-2031
21	89	0.1	4 ^{H6}	RH	BS1050-1036	BS2050-1036	BS3550-1036	
				LH	BS1050-1037	BS2050-1037	BS3550-1037	
21	89	0.2	4 ^{H6}	RH	BS1050-2036	BS2050-2036	BS3550-2036	
				LH	BS1050-2037	BS2050-2037	BS3550-2037	
4	10	78	0.1	4 ^{H6}	RH		BS2050-1132	BS3550-1132
					LH		BS2050-1133	BS3550-1133
	10	78	0.2	4 ^{H6}	RH		BS2050-2132	BS3550-2132
					LH		BS2050-2133	BS3550-2133
	15	80	0.1	4 ^{H6}	RH	BS1050-1140	BS2050-1140	BS3550-1140
					LH	BS1050-1141	BS2050-1141	BS3550-1141
	15	83	0.2	4 ^{H6}	RH	BS1050-2130	BS2050-2130	BS3550-2130
					LH	BS1050-2131	BS2050-2131	BS3550-2131
	21	89	0.1	4 ^{H6}	RH	BS1050-1134	BS2050-1134	BS3550-1038
					LH	BS1050-1135	BS2050-1135	BS3550-1039
	21	89	0.2	4 ^{H6}	RH	BS1050-2134	BS2050-2134	BS3550-2038
					LH	BS1050-2135	BS2050-2135	BS3550-2039
4.5		78	0.1	4 ^{H6}	RH		BS2050-1230	BS3550-1240
					LH		BS2050-1231	BS3550-1241
		78	0.2	4 ^{H6}	RH		BS2050-2230	BS3550-2240
					LH		BS2050-2231	BS3550-2241
		83	0.1	4 ^{H6}	RH	BS1050-1232	BS2050-1232	BS3550-1242
					LH	BS1050-1233	BS2050-1233	BS3550-1243
		83	0.2	4 ^{H6}	RH	BS1050-2232	BS2050-2232	BS3550-2242
					LH	BS1050-2233	BS2050-2233	BS3550-2243
		89	0.1	4 ^{H6}	RH		BS2050-1234	BS3550-1244
					LH		BS2050-1235	BS3550-1245
		89	0.2	4 ^{H6}	RH		BS2050-2234	BS3550-2244
					LH		BS2050-2235	BS3550-2245
5		80	0.1	4 ^{H6}	RH		BS2050-1240	BS3550-1040
					LH		BS2050-1241	BS3550-1041
		80	0.2	4 ^{H6}	RH	BS1050-2040	BS2050-2040	BS3550-2040
					LH	BS1050-2041	BS2050-2041	BS3550-2041
		80	0.4	4 ^{H6}	RH	BS1050-4040	BS2050-4040	BS3550-4040
					LH	BS1050-4041	BS2050-4041	BS3550-4041

PCD / CVD-D / CBN Tipped Bars

BS

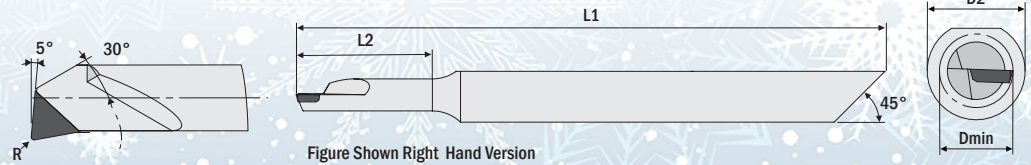

PASSION FOR DIAMOND

Dmin	L2	L1	R	D2	Version	PCD	CVD-D	CBN
						ITEM CODE	ITEM CODE	ITEM CODE
6		100	0.1	5 ^{H6}	RH		BS2050-1050	BS3550-1050
					LH		BS2050-1051	BS3550-1051
		100	0.2	5 ^{H6}	RH	BS1050-2050	BS2050-2050	BS3550-2050
					LH	BS1050-2051	BS2050-2051	BS3550-2051
		100	0.4	5 ^{H6}	RH	BS1050-4050	BS2050-4050	BS3550-4050
					LH	BS1050-4051	BS2050-4051	BS3550-4051
7		100	0.2	6 ^{H6}	RH	BS1050-2060	BS2050-2060	BS3550-2060
					LH	BS1050-2061	BS2050-2061	BS3550-2061
		100	0.4	6 ^{H6}	RH	BS1050-4060	BS2050-4060	BS3550-4060
					LH	BS1050-4061	BS2050-4061	BS3550-4061
9		100	0.2	8 ^{H6}	RH	BS1050-2080	BS2050-2080	BS3550-2080
					LH	BS1050-2081	BS2050-2081	BS3550-2081
		100	0.4	8 ^{H6}	RH	BS1050-4080	BS2050-4080	BS3550-4080
					LH	BS1050-4081	BS2050-4081	BS3550-4081

BE

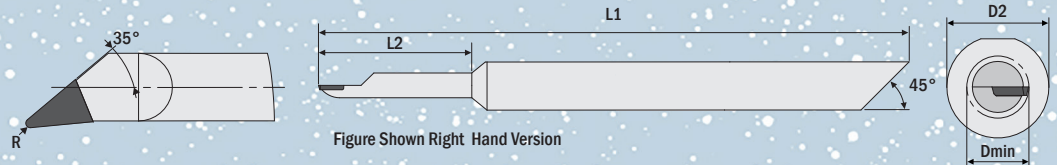

PASSION FOR DIAMOND

Dmin	L2	L1	R	D2	Version	PCD	CVD-D	CBN
						ITEM CODE	ITEM CODE	ITEM CODE
3.6	10	100	0.2	6 ^{H6}	RH		BE2050-2130	BE3550-2130
					LH		BE2050-2131	BE3550-2131
	18	100	0.2	6 ^{H6}	RH		BE2050-2030	BE3550-2030
					LH		BE2050-2031	BE3550-2031
7		100	0.2	6 ^{H6}	RH		BE2050-2060	BE3550-2060
					LH		BE2050-2061	BE3550-2061
		100	0.4	6 ^{H6}	RH		BE2050-4060	BE3550-4060
					LH		BE2050-4061	BE3550-4061

ADAPTERS



ITEM CODE	D	d	dH7	dH7mm	H	I
ADAP-0.625-40	0.625	0.197	0.157	4	0.551	3.94
ADAP-0.625-50	0.625	0.236	0.197	5	0.551	3.94
ADAP-0.625-60	0.625	0.315	0.236	6	0.551	3.94
ADAP-0.625-80	0.625	0.394	0.315	8	0.551	3.94

Technical Information

PCD	Is ideally suited for the machining of: Aluminium <10% Si Graphite Copper Copper Alloy Magnesium Brass PEEK Tungsten alloy
CVD-D	Is ideally suited for the machining of: Acrylic (PMMA) Aluminum >10% Si Glass, Fiberglass Carbide Ceramics Synthetics Copper, Copper Alloys Magnesium Silver, Gold, Platinum Titanium Composites (CFK, GFK) Zirconium
CBN-H	For the machining of: Steels up to Rc Hardened Sintered Steels

Type BS
Starting from Dmin 1,00mm

All coloured surfaces can be machined

Robust system for turning contours in bores

Type BE
Starting from Dmin 3,60mm

All coloured surfaces can be machined

For contouring turning on the plane surface

Machining Carbide or Sintered Ceramics?

We can help!

We offer a full line of inserts and milling tools for machining these difficult materials. *Call us to discuss our innovative solutions!*

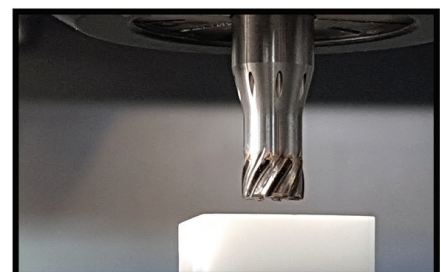
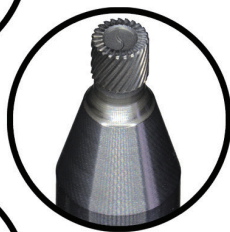



MICRO-Line—Precision Grooving and Profiling PCD, CVD-D, ULT-D, and CBN Tipped inserts

MICRO-Line System | Tool Holder

Benefits:

- Designed for grooving with diamond and CBN cutting materials
- Right side and left side tool holders in different dimensions in stock
- Grooving depth up to 3.80 mm
- For continuous and interrupted cuts
- Stable and precise guiding of the grooving insert
- Easy and quick change of the grooving insert

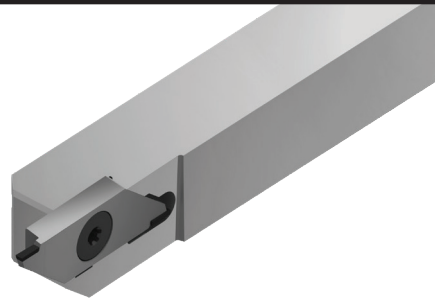

MICRO-Line EST and RST System | Corner and Full Radius Grooving Inserts

Benefits:

- Corner grooving insert, width 1.00 mm to 2.00 mm, tolerance +/- 0.01 mm in stock
- Radii from 0.05 mm to 0.20 mm, tolerance +/- 0.01 mm in stock
- Tipped with 2 cutting edges (on request also with chip breakers)

Micro-EST



- Full radius grooving insert, width 2.00 mm to 6.00 mm, tolerance +/- 0.01 mm in stock
- Full radius from 0.50 mm to 1.00 mm, tolerance +/- 0.01 mm in stock
- Tipped with 2 cutting edges (on request also with chip breakers)
- Cutting edge length 3.00 mm

Micro-RST

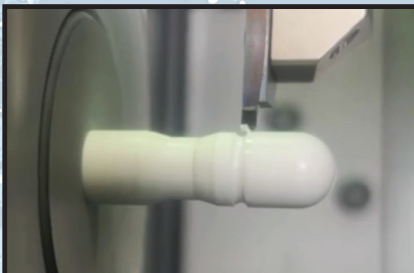

Micro-Line 1mm rad.
Cutting Zirconium Oxide



Scan for Video!

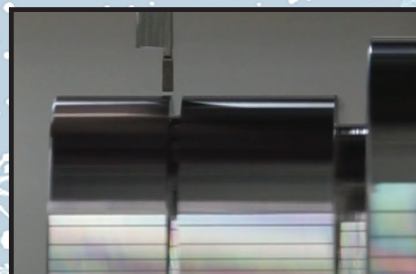

Micro-Line 1mm wide
Cutting 55 Rc Steel



Scan for Video!

Micro-Line Toolholder System

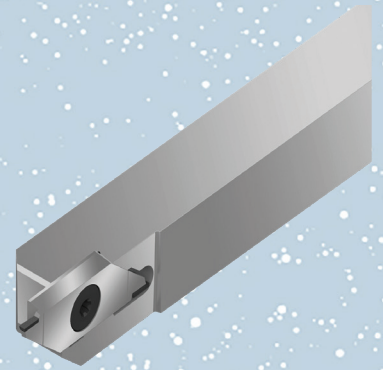
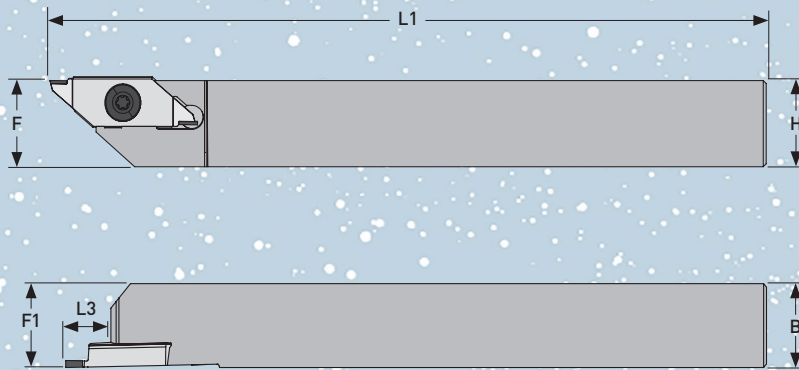
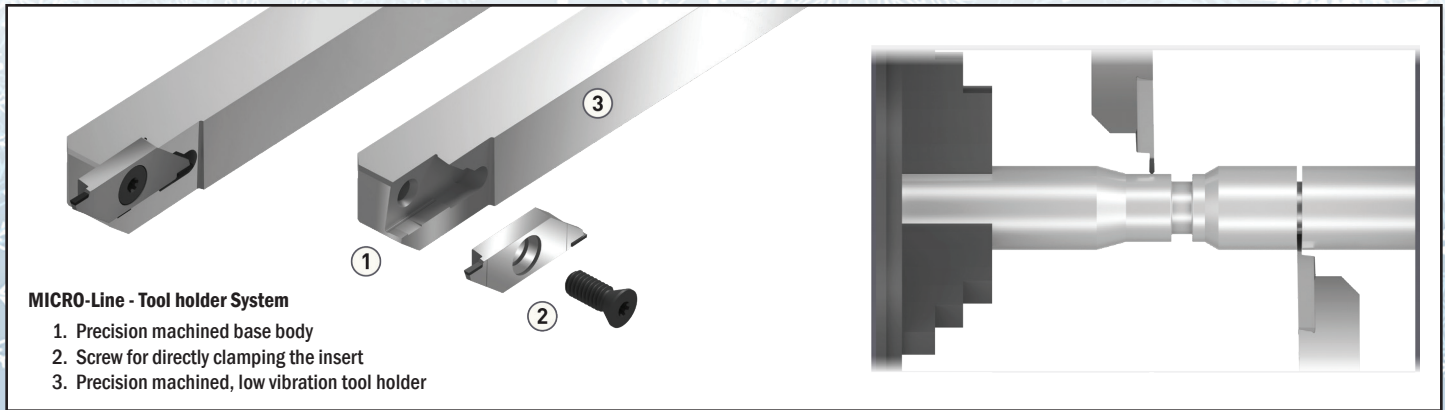

INCH

Designation	B	H	L1	L3	F	F1	Version
PGER-0375K	.375	.375	4.900	.310	.380	.380	RH
PGEL-0375K							LH
PGER-0500K	.500	.500	4.900	.310	.500	.500	RH
PGEL-0500K							LH
PGER-0625K	.625	.625	4.900	.310	.630	.630	RH
PGEL-0625K							LH

METRIC

Designation	B	H	L1	L3	F	F1	Version
ST7060-0010	8	8	125	8	10	10	RH
ST7060-0015							LH
ST7060-0020	10	10	125	8	10	10	RH
ST7060-0025							LH
ST7060-0030	12	12	125	8	12	12	RH
ST7060-0035							LH
ST7060-0040	16	16	125	8	16	16	RH
ST7060-0045							LH
ST7060-0050	20	20	125	8	20	20	RH
ST7060-0055							LH

Micro-Line Indexable Grooving Inserts System

MICRO-Line - Indexable Grooving Insert

Benefits:

- Laser cut diamond or CBN cutting edge
- High vacuum brazed
- Precision machined carbide base body
- Precision machined center bore
- Tangential clamping provides the best stability
- Two cutting edges (Z2)
- In cutting materials: PCD / CVD-D / UltraDiamond / CBN

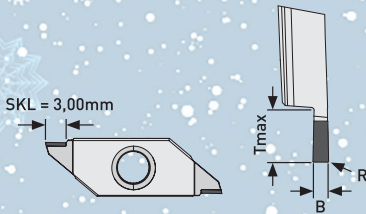
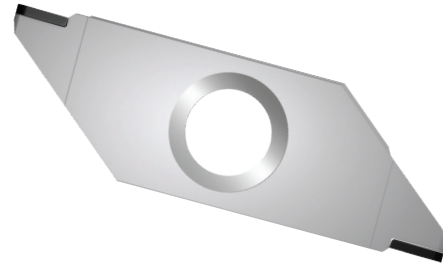

2-edge grooving and profile turning inserts
Figure shows right version

SQUARE END

				PCD	CVD-D	U-DIA	CBN-H	CBN-X	CBN-K
B	R	Tmax	R/L	Item Code	Item Code	Item Code	Item Code	Item Code	Item Code
1	0.05	2.7	RH	ST1050-2100	ST2050-2100	ST1950-2100	ST5050-2100	ST5950-2100	ST5550-2100
			LH	ST1050-2101	ST2050-2101	ST1950-2101	ST5050-2101	ST5950-2101	ST5550-2101
	0.1	2.7	RH	ST1050-2102	ST2050-2102	ST1950-2102	ST5050-2102	ST5950-2102	ST5550-2102
			LH	ST1050-2103	ST2050-2103	ST1950-2103	ST5050-2103	ST5950-2103	ST5550-2103
1.5	0.05	3.8	RH	ST1050-2150	ST2050-2150	ST1950-2150	ST5050-2150	ST5950-2150	ST5550-2150
			LH	ST1050-2151	ST2050-2151	ST1950-2151	ST5050-2151	ST5950-2151	ST5550-2151
	0.1	3.8	RH	ST1050-2152	ST2050-2152	ST1950-2152	ST5050-2152	ST5950-2152	ST5550-2152
			LH	ST1050-2153	ST2050-2153	ST1950-2153	ST5050-2153	ST5950-2153	ST5550-2153
2	0.05	3.8	RH	ST1050-2200	ST2050-2200	ST1950-2200	ST5050-2200	ST5950-2200	ST5550-2200
			LH	ST1050-2201	ST2050-2201	ST1950-2201	ST5050-2201	ST5950-2201	ST5550-2201
	0.1	3.8	RH	ST1050-2202	ST2050-2202	ST1950-2202	ST5050-2202	ST5950-2202	ST5550-2202
			LH	ST1050-2203	ST2050-2203	ST1950-2203	ST5050-2203	ST5950-2203	ST5550-2203
	0.2	3.8	RH	ST1050-2204	ST2050-2204	ST1950-2204	ST5050-2204	ST5950-2204	ST5550-2204
			LH	ST1050-2205	ST2050-2205	ST1950-2205	ST5050-2205	ST5950-2205	ST5550-2205

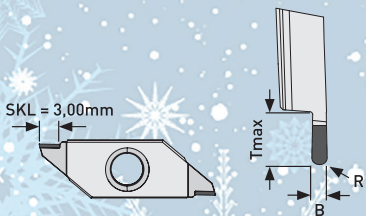







2-edge grooving and profile turning inserts
Figure shows right version

RADIUS END

				PCD	CVD-D	U-DIA	CBN-H	CBN-X	CBN-K
B	R	Tmax	R/L	Item Code	Item Code	Item Code	Item Code	Item Code	Item Code
1	0.5	2.7	RH	ST1050-3100	ST2050-3100	ST1950-3100	ST5050-3100	ST5950-3100	ST5550-3100
			LH	ST1050-3101	ST2050-3101	ST1950-3101	ST5050-3101	ST5950-3101	ST5550-3101
1.5	0.75	3.8	RH	ST1050-3150	ST2050-3150	ST1950-3150	ST5050-3150	ST5950-3150	ST5550-3150
			LH	ST1050-3151	ST2050-3151	ST1950-3151	ST5050-3151	ST5950-3151	ST5550-3151
2	1	3.8	RH	ST1050-3200	ST2050-3200	ST1950-3200	ST5050-3200	ST5950-3200	ST5550-3200
			LH	ST1050-3201	ST2050-3201	ST1950-3201	ST5050-3201	ST5950-3201	ST5550-3201

Technical Information

 <p>PCD Diamant</p> <p>Applications:</p> <ul style="list-style-type: none"> • Aluminium < 10%Si • Copper / Tungsten Copper • CFRP / GFRP Sandwich Materials • Graphite 	 <p>CBN-H</p> <p>Applications:</p> <ul style="list-style-type: none"> • Hardened Steels up to a hardness of 72 HRC • Sintered Steel hardened
 <p>CVD-D Diamant</p> <p>Applications:</p> <ul style="list-style-type: none"> • Carbide G-Grade >12% Co • Carbide K-Grade >15% Co • Ceramics / Glass-ceramic • Aluminium > 10% Si • Fused Silica / Glass • Titanium (Finishing operations) • Copper / Tungsten Copper • CFRP / GFRP Sandwich Materials • Glass / Plexiglass • Abrasive non-ferrous materials • Other brittle non-ferrous materials 	 <p>CBN-X</p> <p>Applications:</p> <ul style="list-style-type: none"> • Tool Steel hardened up to 72 HRC • Stellite • Tungsten Carbide > 20%
 <p>Ultra Diamant</p> <p>Applications:</p> <ul style="list-style-type: none"> • Carbide G-Grade >12% Co • Carbide K-Grade >7% Co • Carbide with Ni Binder • Ceramics / Glass-ceramic • Fused Silica / Glass • Other brittle non-ferrous materials 	 <p>CBN-K</p> <p>Applications:</p> <ul style="list-style-type: none"> • Cast Iron • Nodular Graphite Cast Iron

For even more grooving options, check out our Eco-Line series tools

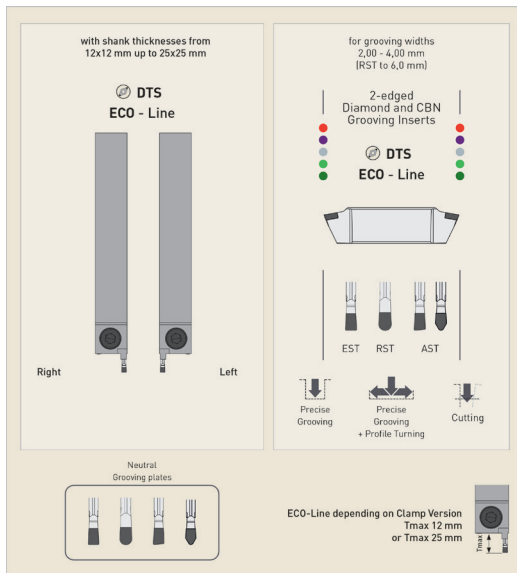

- Laser cut diamond or CBN edges
- Two cutting edges per insert
- Square End, Full radius, Cut-Off Chamfering geometries
- From 2.0mm to 6.0mm widths
- Available in PCD, CVD-D Diamond Tips
- Also available in CBN-H, CBN-K, CBN-X tips for wide application range
- Large range of holders (Metric Only)

New Tool Design!



Inserts From

DTS GmbH

Diamond Tooling Systems

- Ultra precise finishing with two different insert wiper configurations and micro-adjustable cartridges to produce the ultimate surface finishes
- Maxicool through coolant for maximum chip evacuation and temperature control
- Milling bodies made from lightweight 7075-T6 aluminum
- Two diamond grades PCD and CVD-D
- Three CBN grades to machine a wide range of materials
- Two cutting edges per insert with 3mm, 3.5mm & 6mm cutting edge lengths

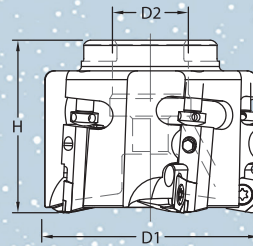

TCP90 Face Mills for PCD / TFC Milling Applications



















Designation	D1	D2	H	Flutes	Insert	Cartridge	Cartridge Screw	Insert Screw	Height Adj. Screw
TCP90-2000-AL	2.00	.75	2.00	3	CPGX-32.5...	BC100X5000 BRTC	M5 SHCS	TCP951	HAS6823
TCP90-2500-AL	2.50	1.00	2.00	5					
TCP90-3000-AL	3.00	1.00	2.00	7					
TCP90-4000-AL	4.00	1.25	2.00	10					
TCP90-5000-AL	5.00	1.50	2.50	11					
TCP90-6000-AL	6.00	1.50	2.50	13					
TCP90-8000-AL	8.00	2.00	2.50	16					

* Steel cutter bodies are available on request and are recommended when using CBN Tipped Inserts

	Designation	Cut Length	Radius	GRADES				
				PCD	CVD-D	CBN-H	CBN-K	CBN-X
	CPGX-32.50.5PDR-35	.138"	.008"	■	■	■	■	■
	CPGX-32.51PDR-35	.138"	.016"	■	■	■	■	■
	CPGX-32.52PDR-35	.138"	.032"	■	■	■	■	■
	CPGX-32.53PDR-35	.138"	.047"	■	■	■	■	■
	CPGX-32.50.5PDR-60	.236"	.008"	■	■	■	■	■
	CPGX-32.51PDR-60	.236"	.016"	■	■	■	■	■
	CPGX-32.52PDR-60	.236"	.032"	■	■	■	■	■
	CPGX-32.53PDR-60	.236"	.047"	■	■	■	■	■
	CPGX-32.50.5SFR-30	.118"	.008"	■	■	■	■	■
	CPGX-32.51SFR-30	.118"	.016"	■	■	■	■	■
	CPGX-32.52SFR-30	.118"	.032"	■	■	■	■	■
	CPGX-32.53SFR-30	.118"	.047"	■	■	■	■	■

Technical Information

High Performance Grades

PCD	is ideally suited for the machining of * Aluminum <10% Si Brass Copper, Copper Alloys Graphite Magnesium PEEK Tungsten alloy	  
CVD-D	is ideally suited for the machining of * Acrylic (PMMA) Aluminum >10% Si Carbide Ceramics Composites (GFRP/CFRP) Copper, Copper Alloys Glass, Glass ceramic Magnesium Plastic Silver, Gold, Platinum Titanium Zirconium	  
CBN-H	is ideally suited for the machining of * Steel, hardened up to 72 HRC Sinter Steel, hardened	  
CBN-K	is ideally suited for the machining of * Powder metallurgical Steel, hardened Special Alloys such as ASP, CPM, Hardox Tool Steel, hardened up to 72 HRC	  
CBN-X	is ideally suited for the machining of * Grey Cast Iron (GCI) Ductile Cast Iron (DCI)	  
 Continuous Cut  Light Interrupted Cut  Heavy Interrupted Cut		

Security & Performance Features

Micro Adjustable

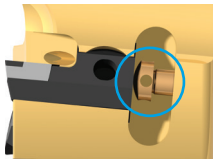

Easily pre-set cartridges to within microns
All new milling cutters are factory pre-set in height to within ± 0.0004 with a master gauge insert

Through Coolant Enabled

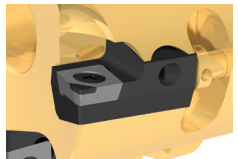

Coolant ports are directed at the cutting edge to extend tool life and improve surface finishes

Cartridge Dovetail Lock

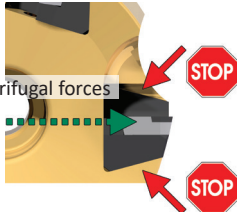

Insert cartridge is fitted into cutter body with dovetail design
Centrifugal forces acting on insert cartridge are neutralized by wedge profile of cartridge and matching shape on cutter body

Wiper Radius



Unique wiper is a compound radius that outperforms traditional wiper flats
With every insert in the cutter loaded with the wiper radius, super finishing is easily attained

ISO	Material	PCD	CVD-D	CBN-H	CBN-X	CBN-K
H	Powder metallurgical Steel, hardened			●	●	
	Special Alloys (ASP,CPM,Hardox)			●	●	
	Steel, hardened up to 72 HRC			●	●	
	Tool Steel, hardened up to 72 HRC			●	●	
P	Sintered Steel				●	●
	Sintered Steel, hardened			●	●	
K	Grey Cast Iron (GCI)					●
	Ductile Cast Iron (DCI)				●	●
	Shell Chilled Cast Iron			●	●	
S	Ni-, Co-, Fe- and Cr-Alloys			●	●	
	Titanium Alloys			●	●	
M	Stainless Steel, hardened			●	●	
N	Acrylic (PMMA)		●			
	Aluminum, < 10% Si	●	●			
	Aluminum, > 10% Si	●	●			
	Brass	●	●			
	Ceramics	●	●			

ISO	Material	PCD	CVD-D	CBN-H	CBN-X	CBN-K
N	Ceramics (Green)	●	●			
	Plastics	●	●			
	Composite such as CFG/GFRP	●	●			
	Copper, Copper Alloys	●	●			
	Glass, Glass Ceramic	●	●			
	Graphite	●	●			
	Magnesium	●	●			
	MMC	●	●			
	PEEK	●	●			
	Silver, Gold, Platinum	●	●			
	Tungsten alloy	●	●			
	Zirconium	●	●			



DTS GmbH

Diamond Tooling Systems



Welcome to DTS GmbH - Diamond Tooling Systems!

Based in Kaiserslautern, Germany, we specialize in the development, manufacture and sale of precision tools equipped with ultra-hard cutting materials such as PCD (Polycrystalline Diamond), CVD-D (CVD Thick Film Diamond), UltraDiamond (Binderless) and CBN (Cubic Boron Nitride).

As a leading manufacturer of tools with laser-cut cutting edges, we offer machining solutions in the areas of turning, milling, grooving, drilling, reaming and tool holders.

In order to be able to economically process ultra-hard cutting materials such as PKD, CVD-D, UltraDiamant (binderless) and CBN on precision tools, we recognized early on that we had to develop from the old production technology "grinding" to new technologies such as the "laser ablation process".

In the meantime, our customers confirm us as the leading manufacturer of laser-cut tools for metal cutting.

Ultra-hard, high-performance cutting materials play a key role in machining. Precision tools equipped with ultra-hard cutting materials are products that require a lot of explanation. The economical use of the cutting materials can only be ensured if the machining process and the cutting material are coordinated.

This is exactly where we as DTS - Diamond Tooling Systems GmbH come in, "Our core competence is precision tools equipped with ultra-hard cutting materials". These high-tech tools have to be precisely coordinated with application engineers for the machining process.

Tools and processes are comprehensively analysed by our experienced application engineers, the new well thought-out, tailor-made process optimisation is presented to the customer and used together in production in the next step, only in this way is it possible to exploit the optimum potential of the high-hard cutting materials.

With more than 25 years of optimization experience in the manufacturing industry, this is where we see our strength!

During ongoing production, we are at your side with our experienced application engineers. This close cooperation and mutual trust is the basis of our success.

RTC **Rani Tool Corp.**

320 Troy Circle, Unit C, Knoxville, TN 37919

Tel: (865) 337-7799 or (888) 554-RANI • Fax: (865) 337-7716

E-mail: sales@ranitool.com • www.ranitool.com

Available From: