

Dynamic Milling Program

Ty Carb

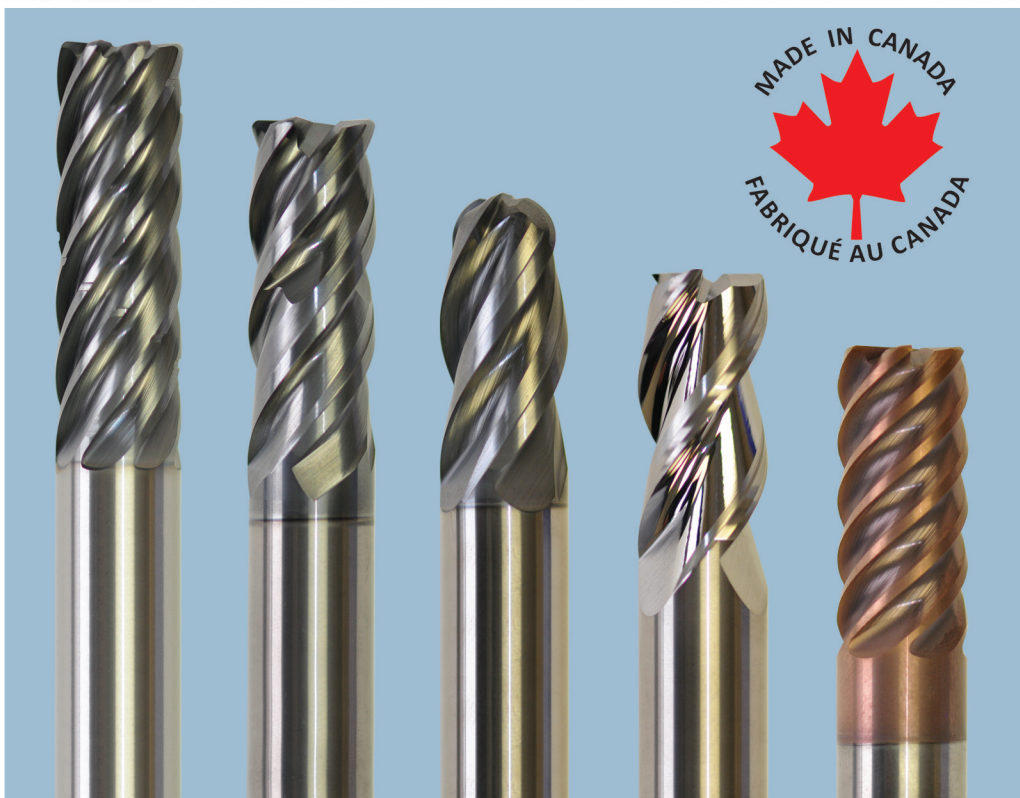

MADE IN CANADA
FABRIQUÉ AU CANADA



Dynamic & Trochoidal Milling Technical

The maximum recommended engagement ratio, based on material group, for trochoidal/dynamic milling can be seen in the chart below.

Maximum Recommended Radial Engagement	
ae / D	Material Group
20% (53.15)	Carbon Steel / Alloy Steel
20% (53.15)	Stainless Steel
20% (53.15)	Cast Iron
10% (36.87)	Super Alloys
16% (47.20)	Hard Machining

****Based on 3xD length of cut****

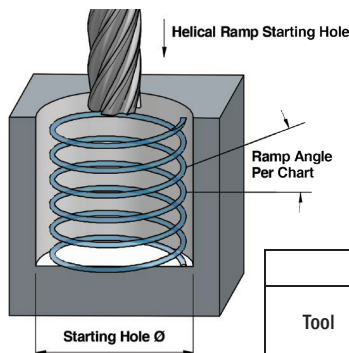

A helical ramp entry is the preferred method to enter into the middle of a part. The table shows the factors to the speed and feed charts below. The maximum entry hole diameter is calculated as 2x tool dia. - 2x corner radius.

Helical Ramp Entry				
Tool	Speed (SFM)	Feed Factor with air / low pressure coolant	Feed Factor with high pressure coolant	Ramp Angle
Stratus 5	As Per Chart	IPT x 1.25	IPT x 1.6	0.5 deg
Stratus 7	As Per Chart	IPT x 1.25	IPT x 1.6	0.5 deg

Diameter of the starting hole will be (2 x tool diameter) - (2 x corner radius)

Trochoidal Milling Adjustment Factors in the chart shown can be applied to the speed and feed chart based on engagement ratio ae / D (engagement angle) being used.

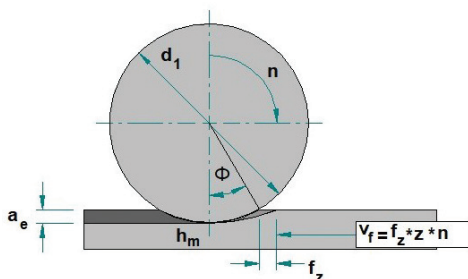

Trochoidal Milling Factors		
ae	Fz Factor	SFM Factor
4% (23.07)	3	3
5% (25.84)	2.5	2
10% (36.87)	2	1.8
20% (53.15)	1.4	1.5
30% (66.42)	1.2	1.2

For 3xD increase values by 10%. For 2xD increase values by 20%

STRATUS ST5X & ST7X Recommended Cutting Parameters for Dynamic / Trochoidal Milling								
Work Material	ap	Cutting Speed (SFM)		Baseline feed per flute (factors need to be applied)				
		Min	Max	3/8	1/2	5/8	3/4	1
Low Carbon Steels < 38 Rc 1018, 12L14, 8620	4 x D	480	650	.0025	.0032	.0037	.0041	.0048
Medium & High Carbon Carbon Steels <35 Rc 1045, 1050, 1525, 1545	4 x D	450	625	.0025	.0032	.0038	.0043	.0048
Alloy Steels & Tool Steels <35 Rc 4000 series, 5000 series P20, H13, A2, D2	4 x D	400	525	.0021	.0027	.0032	.0036	.0042
Alloy Steels & Tool Steels <48 Rc 4000 series, 5000 series P20, H13, A2, D2	4 x D	300	475	.0019	.0024	.0029	.0033	.0038
Martensitic & Ferritic Stainless Steels <35 Rc 13-8 PH, 15-5 PH, 17-4 PH, 400 & 500 series	4 x D	200	325	.0016	.0021	.0025	.0029	.0034
Martensitic & Ferritic Stainless Steels <48 Rc 13-8 PH, 15-5 PH, 17-4 PH, 400 & 500 series	4 x D	150	225	.0013	.0017	.0019	.0023	.0026
Austenitic Stainless Steels 200 Series, 304, 304L, 309	4 x D	310	375	.0021	.0027	.0032	.0036	.0042
High Strength Stainless Steels 310, 316, 316L	4 x D	200	260	.0017	.0021	.0025	.0029	.0034
Duplex Stainless Steels F55, 323, 2205	4 x D	200	240	.0013	.0017	.0021	.0023	.0026
Gray Cast Iron GG15, GG25, GG30, GG40	4 x D	390	500	.0025	.0032	.0036	.0042	.0048
Low to Medium Strength Ductile Cast Iron GGG40, GTS35	4 x D	360	460	.0021	.0027	.0032	.0038	.0043
High Strength Ductile Iron GGG60, GTW55, GTS65	4 x D	330	430	.0016	.0021	.0025	.0029	.0034
Titanium Alloys	4 x D	150	200	.0015	.0019	.0023	.0026	.0031
High Temperature Alloys Inconel, Haynes, Stellite, Hastalloy	4 x D	120	170	.0015	.0019	.0023	.0029	.0034
Hardened Steel 44 - 48 Rc H11, H13, 4340, P20	4 x D	250	450	.0019	.0024	.0029	.0033	.0038
Hardened Steel 49 - 54 Rc H11, H13, 4340, P20	4 x D	225	380	.0013	.0017	.0022	.0025	.0028

Notes: Recommended cutting parameters in chart are a baseline to be used for Trochoidal Milling application. Speeds and feeds need to be adjusted based on percentage of radial engagement using the factors in tables provided to maintain correct chip thickness. When using ST7 3 x D feeds can be increased 20% before factors are applied.

Dynamic & Trochoidal Milling Capabilities of ST5XC & ST7XC Multi-Flute End Mills



The Ty-Carb Stratus ST7XC is a high performance line of carbide end mills that are designed with a unique geometry and chip splitters developed specifically for trochoidal / dynamic milling. These new HSC endmills are designed to maximize performance over traditional machining practices. The Stratus 7 is available in 2xD, 3xD and 4xD for proper optimization of your part and taking full advantage of your machine capabilities.

The ST5XC series of end mills are primarily designed for finishing applications and do not include chip splitters. They are however an excellent choice for both Dynamic or Trochoidal milling when machine and application calls for 5 flute high performance end mills.

Both the ST5XC & the ST7XC families of end mills have a honed cutting edge as well as a Post-Process treatment after Coating to improve chip flow while also reversing the stresses created in the Coating process.

Advantages of Trochoidal / Dynamic Milling

- Axial depth of cut 2xD – 4xD (utilizing the full edge of the endmill)
- Particularly suited for difficult to machine materials
- Reduced thermal stresses due to lower heat generated Increased cutting speeds possible
- Increased feed rates possible
- Machining of unstable or thin walled work pieces
- Optimized metal removal rates for light duty machines
- Reduced power requirements
- Lower risk of spindle damage due to reduced torque fluctuations

STRATUS 5 Flute End Mills

The STRATUS family of Premium end mills bring a new performance level to machining of todays difficult to machine materials. We have incorporated many of the advanced features necessary to achieve superior results

- Premium Micro-grain carbide substrate
- Next generation AlCrN PVD coating
- 5 flute Differential spacing for smooth cutting performance
- Variable Helix design to combat vibration & chatter
- Designed to Slot at 1 x D
- Eccentric Relief for improved edge strength
- Tapered core for added stability
- All STRATUS end mills are Post Processed after coating to achieve improved tool performance



STRATUS 5 Flute High Performance Cylindrical Shank End Mills

Designation	Dia.	Shank Dia.	LOC	OAL	Radius	TL30 Coated
ST5RC-SQ0187	3/16	3/16	5/8	2	---	●
ST5RC-SQ0187-015	3/16	3/16	5/8	2	.015	●
ST5EC-SQ0187	3/16	3/16	7/8	2.1/2	---	●
ST5RC-SQ0250	1/4	1/4	3/4	2.1/2	---	●
ST5RC-SQ0250-020	1/4	1/4	3/4	2.1/2	.020	●
ST5RC-SQ0250-030	1/4	1/4	3/4	2.1/2	.030	●
ST5RC-SQ0250-060	1/4	1/4	3/4	2.1/2	.060	●
ST5RC-SQ0312	5/16	5/16	13/16	2.1/2	---	●
ST5RC-SQ0312-020	5/16	5/16	13/16	2.1/2	.020	●
ST5RC-SQ0375	3/8	3/8	7/8	2.1/2	---	●
ST5RC-SQ0375-020	3/8	3/8	7/8	2.1/2	.020	●
ST5RC-SQ0375-030	3/8	3/8	7/8	2.1/2	.030	●
ST5RC-SQ0375-060	3/8	3/8	7/8	2.1/2	.060	●
ST5RC-SQ0375-120	3/8	3/8	7/8	2.1/2	.120	●
ST5EC-SQ0375	3/8	3/8	1.1/8	3	---	●
ST5EC-SQ0375-020	3/8	3/8	1.1/8	3	.020	●
ST5SC-SQ0500	1/2	1/2	5/8	2.1/2	---	●
ST5RC-SQ0500	1/2	1/2	1	3	---	●
ST5RC-SQ0500-020	1/2	1/2	1	3	.020	●
ST5RC-SQ0500-030	1/2	1/2	1	3	.030	●
ST5RC-SQ0500-060	1/2	1/2	1	3	.060	●
ST5EC-SQ0500	1/2	1/2	1.1/4	3	---	●
ST5EC-SQ0500-015	1/2	1/2	1.1/4	3	.015	●
ST5EC-SQ0500-020	1/2	1/2	1.1/4	3	.020	●

Designation	Dia.	Shank Dia.	LOC	OAL	Radius	TL30 Coated
ST5EC-SQ0500-030	1/2	1/2	1.1/4	3	.030	●
ST5EC-SQ0500-060	1/2	1/2	1.1/4	3	.060	●
ST5EC-SQ0500-090	1/2	1/2	1.1/4	3	.090	●
ST5EC-SQ0500-120	1/2	1/2	1.1/4	3	.120	●
ST5RC-SQ0562	9/16	9/16	1.1/4	3.1/2	---	●
ST5RC-SQ0625	5/8	5/8	1.1/4	3.1/2	---	●
ST5RC-SQ0625-030	5/8	5/8	1.1/4	3.1/2	.030	●
ST5RC-SQ0625-060	5/8	5/8	1.1/4	3.1/2	.060	●
ST5EC-SQ0625	5/8	5/8	1.5/8	3.1/2	---	●
ST5EC-SQ0625-030	5/8	5/8	1.5/8	3.1/2	.030	●
ST5RC-SQ0750	3/4	3/4	1.1/2	4	---	●
ST5RC-SQ0750-030	3/4	3/4	1.1/2	4	.030	●
ST5RC-SQ0750-060	3/4	3/4	1.1/2	4	.060	●
ST5RC-SQ0750-090	3/4	3/4	1.1/2	4	.090	●
ST5RC-SQ0750-120	3/4	3/4	1.1/2	4	.120	●
ST5EC-SQ0750	3/4	3/4	1.3/4	4	---	●
ST5EC-SQ0750-030	3/4	3/4	1.3/4	4	.030	●
ST5EC-SQ0750-060	3/4	3/4	1.3/4	4	.060	●
ST5EC-SQ0750-120	3/4	3/4	1.3/4	4	.120	●
ST5RC-SQ1000	1	1	1.1/2	4	---	●
ST5RC-SQ1000-030	1	1	1.1/2	4	.030	●
ST5RC-SQ1000-060	1	1	1.1/2	4	.060	●
ST5RC-SQ1000-120	1	1	1.1/2	4	.120	●

STRATUS 5 Flute Extended End Mills

STRATUS 5 Flute Extended End Mills

Designation	Dia.	Shank Dia.	LOC	OAL	Radius	TL30 Coated
ST5X4C-SQ0375	3/8	3/8	1.1/2	3.1/2	---	●
ST5X4C-SQ0375-030	3/8	3/8	1.1/2	3.1/2	.030	●
ST5X4C-SQ0375-060	3/8	3/8	1.1/2	3.1/2	.060	●
ST5X4C-SQ0500	1/2	1/2	2	4	---	●
ST5X4C-SQ0500-030	1/2	1/2	2	4	.030	●
ST5X4C-SQ0500-060	1/2	1/2	2	4	.060	●
ST5X4C-SQ0500-120	1/2	1/2	2	4	.120	●
ST5X4C-SQ0625	5/8	5/8	2.1/2	5	---	●
ST5X4C-SQ0625-030	5/8	5/8	2.1/2	5	.030	●
ST5X4C-SQ0750	3/4	3/4	3	6	---	●
ST5X4C-SQ0750-030	3/4	3/4	3	6	.030	●
ST5X4C-SQ0750-060	3/4	3/4	3	6	.060	●
ST5X4C-SQ0750-120	3/4	3/4	3	6	.120	●
ST5X4C-SQ1000	1	1	4	7	---	●
ST5X4C-SQ1000-030	1	1	4	7	.030	●
ST5X4C-SQ1000-060	1	1	4	7	.060	●
ST5X4C-SQ1000-120	1	1	4	7	.120	●

- Differential Flute spacing
- Eccentric Relief for improved edge strength
- Tapered core for added stability
- Post Process treatment after coating
- Designed for HSC (High Speed Cutting)
- Ideal tool for Dynamic / Trochoidal milling



STRATUS ST5X & ST7X Recommended Cutting Parameters for Finishing Applications

Work Material	Type of Cut Side Milling		Cutting Speed (SFM)		Feed per flute (Inch)				
	ap	ae	Min	Max	3/8	1/2	5/8	3/4	1
Low Carbon Steels < 38 Rc 1018, 12L14, 8620	4 x D	0.05 x D	975	1300	.0026	.0036	.0040	.0045	.0050
Medium & High Carbon Carbon Steels <35 Rc 1045, 1050, 1525, 1545	4 x D	0.05 x D	900	1225	.0026	.0036	.0040	.0045	.0050
Alloy Steels & Tool Steels <35 Rc 4000 series, 5000 series P20, H13, A2, D2	4 x D	0.05 x D	600	975	.0024	.0030	.0035	.0040	.0047
Alloy Steels & Tool Steels <48 Rc 4000 series, 5000 series P20, H13, A2, D2	4 x D	0.05 x D	585	950	.0020	.0025	.0030	.0035	.0040
Martensitic & Ferritic Stainless Steels <35 Rc 13-8 PH, 15-5 PH, 17-4 PH, 400 & 500 series	4 x D	0.05 x D	385	650	.0017	.0022	.0026	.0030	.0035
Martensitic & Ferritic Stainless Steels <48 Rc 13-8 PH, 15-5 PH, 17-4 PH, 400 & 500 series	4 x D	0.05 x D	335	485	.0015	.0018	.0021	.0024	.0027
Austenitic Stainless Steels 200 series, 304, 304L	4 x D	0.05 x D	590	750	.0022	.0028	.0033	.0038	.0045
High Strength Austenitic Stainless Steels 316, 316L	4 x D	0.05 x D	390	525	.0017	.0022	.0026	.0030	.0036
Duplex Stainless Steels F55, 323, 2205	4 x D	0.05 x D	335	485	.0015	.0018	.0021	.0024	.0027
Gray Cast Iron GG15, GG25, GG30, GG40	4 x D	0.05 x D	795	985	.0026	.0036	.0040	.0043	.0050
Low to Medium Strength Ductile Cast Iron GGG40, GTS35	4 x D	0.05 x D	725	850	.0027	.0030	.0034	.0039	.0045
High Strength Ductile Iron GGG60, GTW55, GTS65	4 x D	0.05 x D	650	840	.0017	.0022	.0027	.0030	.0035
Titanium Alloys	4 x D	0.05 x D	325	385	.0016	.0022	.0025	.0028	.0032
High Temperature Alloys Inconel, Haynes, Stellite, Hastalloy	4 x D	0.05 x D	165	385	.0012	.0018	.0024	.0028	.0032
Hardened Steel 44 - 48 Rc H11, H13, 4340, P20	4 x D	0.05 x D	470	525	.0020	.0025	.0030	.0034	.0040

Notes: Do not exceed an overall radial width of cut (ae) greater than 0.035" when using the above data. Use lower value cutting speed for higher hardness or stock removal. Use higher value cutting speed for lower hardness. Adjust values for smaller taper machines.

STRATUS 2xD, 3xD & 4xD 7 Flute End Mills

- Differential Flute spacing
- Eccentric Relief for improved edge strength
- Tapered core for added stability
- Next Generation AlCrN PVD Coating
- Post Process treatment after coating
- Designed for HSC (High Speed Cutting)
- Ideal tool for dynamic / trochoidal milling
- Supplied with Chip Management Grooves
- Extended Cut length of 2, 3 or 4 times diameter

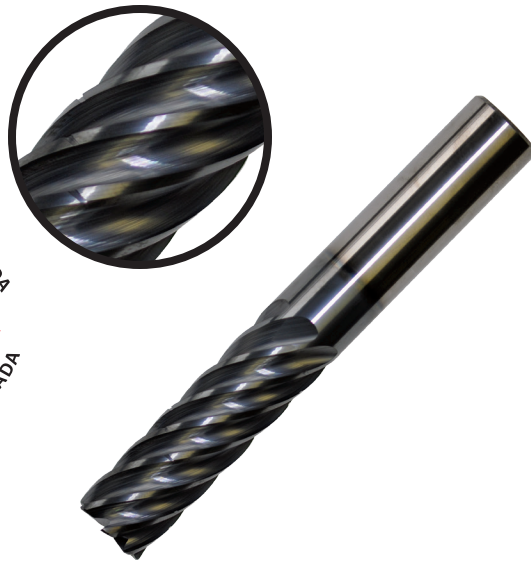

STRATUS 7 Flute End Mills (2xD)

Designation	Dia.	Shank Dia.	LOC	OAL	Radius	TL30 Coated
ST7X2C-SQ0375	3/8	3/8	3/4	2.1/2	---	●
ST7X2C-SQ0375-030	3/8	3/8	3/4	2.1/2	.030	●
ST7X2C-SQ0375-060	3/8	3/8	3/4	2.1/2	.060	●
ST7X2C-SQ0500	1/2	1/2	1	3	---	●
ST7X2C-SQ0500-030	1/2	1/2	1	3	.030	●
ST7X2C-SQ0500-060	1/2	1/2	1	3	.060	●
ST7X2C-SQ0500-090	1/2	1/2	1	3	.090	●
ST7X2C-SQ0500-120	1/2	1/2	1	3	.120	●
ST7X2C-SQ0625	5/8	5/8	1.1/4	3.1/2	---	●
ST7X2C-SQ0625-030	5/8	5/8	1.1/4	3.1/2	.030	●
ST7X2C-SQ0625-060	5/8	5/8	1.1/4	3.1/2	.060	●
ST7X2C-SQ0750	3/4	3/4	1.1/2	4	---	●
ST7X2C-SQ0750-030	3/4	3/4	1.1/2	4	.030	●
ST7X2C-SQ0750-060	3/4	3/4	1.1/2	4	.060	●
ST7X2C-SQ0750-090	3/4	3/4	1.1/2	4	.090	●
ST7X2C-SQ0750-120	3/4	3/4	1.1/2	4	.120	●

STRATUS 7 Flute End Mills (3xD)

Designation	Dia.	Shank Dia.	LOC	OAL	Radius	TL30 Coated
ST7X3C-SQ0375	3/8	3/8	1.1/8	3	---	●
ST7X3C-SQ0375-015	3/8	3/8	1.1/8	3	.015	●
ST7X3C-SQ0375-030	3/8	3/8	1.1/8	3	.030	●
ST7X3C-SQ0375-060	3/8	3/8	1.1/8	3	.060	●
ST7X3C-SQ0500	1/2	1/2	1.1/2	3.1/2	---	●
ST7X3C-SQ0500-030	1/2	1/2	1.1/2	3.1/2	.030	●
ST7X3C-SQ0500-060	1/2	1/2	1.1/2	3.1/2	.060	●
ST7X3C-SQ0500-090	1/2	1/2	1.1/2	3.1/2	.090	●
ST7X3C-SQ0625	5/8	5/8	1.7/8	4.1/2	---	●
ST7X3C-SQ0625-030	5/8	5/8	1.7/8	4.1/2	.030	●
ST7X3C-SQ0750	3/4	3/4	2.1/4	5	---	●
ST7X3C-SQ0750-030	3/4	3/4	2.1/4	5	.030	●
ST7X3C-SQ0750-060	3/4	3/4	2.1/4	5	.060	●
ST7X3C-SQ0750-090	3/4	3/4	2.1/4	5	.090	●
ST7X3C-SQ0750-120	3/4	3/4	2.1/4	5	.120	●
ST7X3C-SQ1000	1	1	3	6	---	●
ST7X3C-SQ1000-030	1	1	3	6	.030	●
ST7X3C-SQ1000-060	1	1	3	6	.060	●
ST7X3C-SQ1000-090	1	1	3	6	.090	●
ST7X3C-SQ1000-120	1	1	3	6	.120	●

STRATUS 7 Flute End Mills (4xD)

Designation	Dia.	Shank Dia.	LOC	OAL	Radius	TL30 Coated
ST7X4C-SQ0375	3/8	3/8	1.1/2	3.1/2	---	●
ST7X4C-SQ0375-030	3/8	3/8	1.1/2	3.1/2	.030	●
ST7X4C-SQ0375-060	3/8	3/8	1.1/2	3.1/2	.060	●
ST7X4C-SQ0500	1/2	1/2	2	4	---	●
ST7X4C-SQ0500-030	1/2	1/2	2	4	.030	●
ST7X4C-SQ0500-060	1/2	1/2	2	4	.060	●
ST7X4C-SQ0500-090	1/2	1/2	2	4	.090	●
ST7X4C-SQ0500-120	1/2	1/2	2	4	.120	●
ST7X4C-SQ0625	5/8	5/8	2.1/2	5	---	●
ST7X4C-SQ0625-030	5/8	5/8	2.1/2	5	.030	●
ST7X4C-SQ0750	3/4	3/4	3	6	---	●
ST7X4C-SQ0750-030	3/4	3/4	3	6	.030	●
ST7X4C-SQ0750-060	3/4	3/4	3	6	.060	●
ST7X4C-SQ0750-090	3/4	3/4	3	6	.090	●
ST7X4C-SQ0750-120	3/4	3/4	3	6	.120	●
ST7X4C-SQ1000	1	1	4	7	---	●
ST7X4C-SQ1000-030	1	1	4	7	.030	●
ST7X4C-SQ1000-060	1	1	4	7	.060	●
ST7X4C-SQ1000-090	1	1	4	7	.090	●
ST7X4C-SQ1000-120	1	1	4	7	.120	●

CUSTOM SOLUTIONS

TV Carb

From simple modifications to standard lines of tooling, to completely engineered tooling solutions - we have the skill, knowledge and expertise to deliver quality products to increase productivity

- Solid Carbide Tooling
- Custom Drills & End Mills
- Custom Form Tools
- Coolant Through G-Drills, & Step Drills
- Special Radii Tooling
- Carbide Reamers
- Jig Boring Tools
- Dovetail Cutters
- Porting Tools
- Coolant Through End Mills
- Spherical End Mills

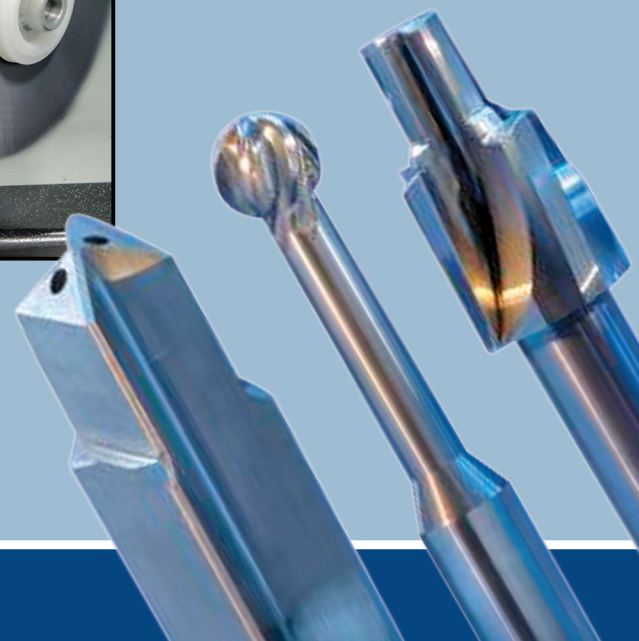

TV Carb

Advanced Cutting Materials
PCD & CBN  Made in Germany

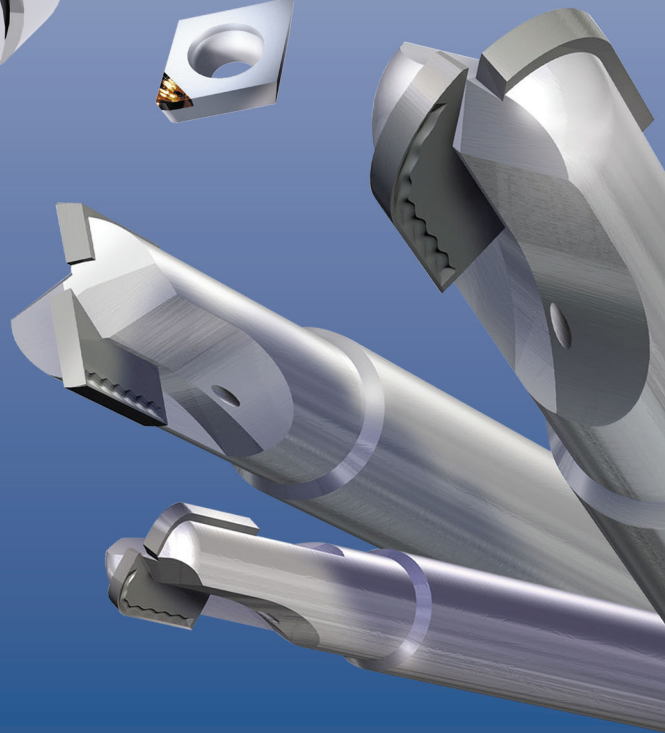
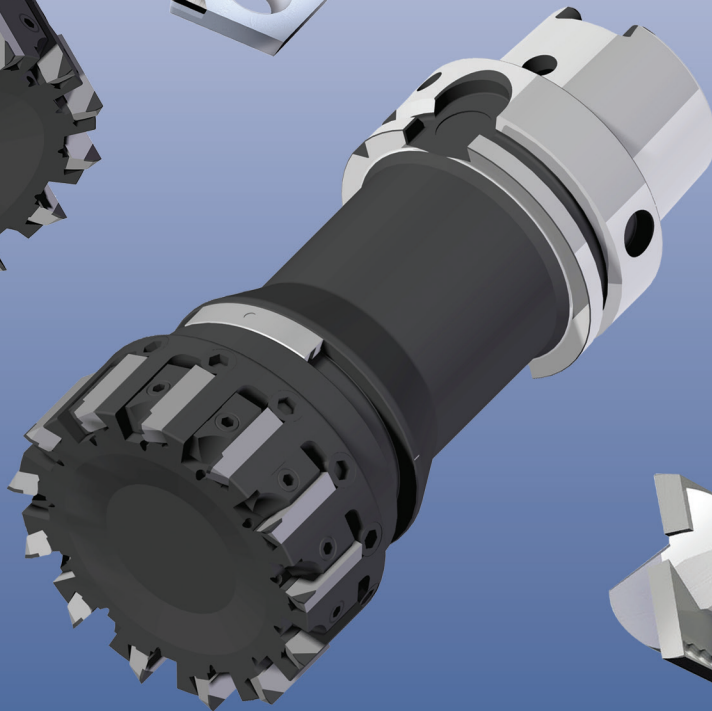
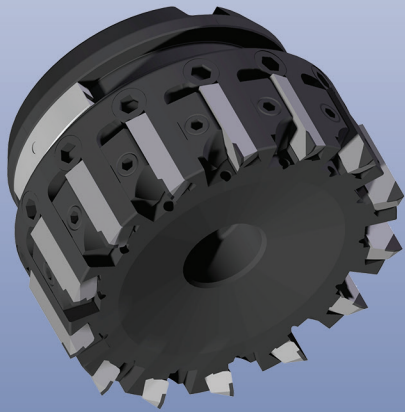

RTC **Rani Tool Corp.**

320 Troy Circle, Unit C, Knoxville, TN 37919

Tel: (865) 337-7799 or (888) 554-RANI • Fax: (865) 337-7716
E-mail: sales@ranitool.com • www.ranitool.com

Available From:

Specifications are subject to change without notice. No responsibility for errors and/or printing errors will be accepted.